



AIR LIQUIDE

TM

OPERATIONS SERVICE MANUAL

Cardox[®]

Carbon Dioxide
Cylinder Filling Unit

S/N 1-042-0050

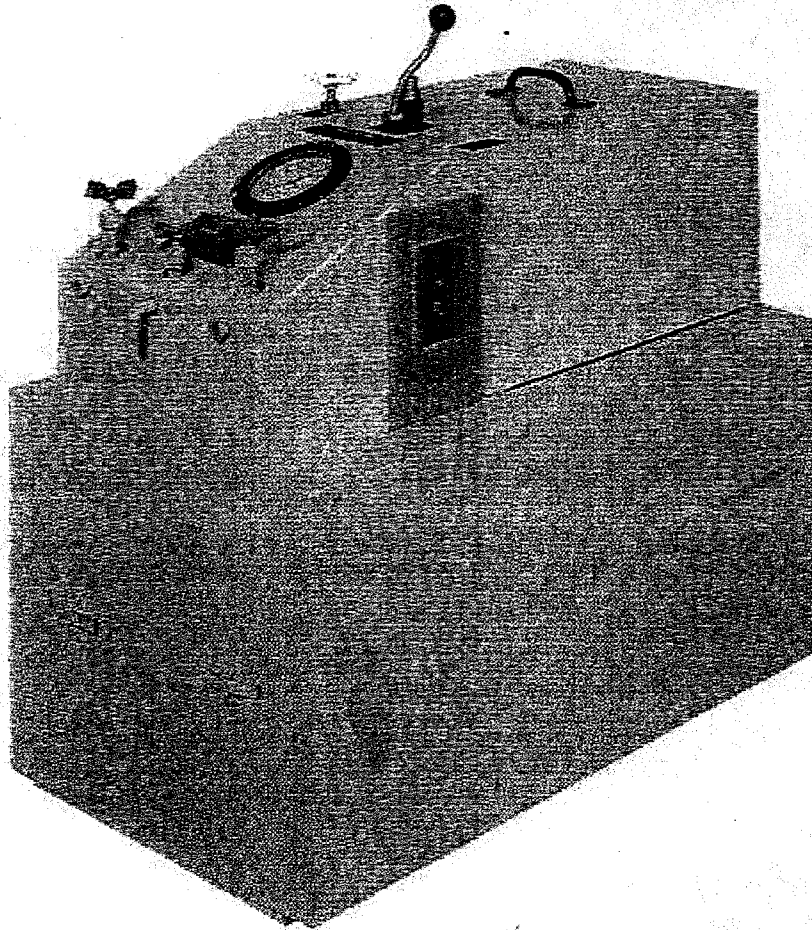

Air Liquide America Corporation

TABLE OF CONTENTS

SECTION	PAGE	SECTION	PAGE
I INTRODUCTION	1	3-5 Alignment	11
1-1 General	1	3-6 Valves	11
1-2 Description of the Cylinder Filling Unit	1	3-7 General	11
II OPERATION AND SERVICE		3-9 Compressor Assembly	11
2-1 Installation of the Cylinder Filling Unit	3	3-10 General	11
2-2 Location	3	3-11 Valves	11
2-3 Unpacking	3	3-12 Disassembly	11
2-4 Equipment Installation	3	3-13 Inspection	12
2-5 Operating Instructions	3	3-14 Reassembly	12
2-6 Cylinder Preparation	3	3-15 Piston Packing Gland	12
2-7 General	3	3-16 General	12
2-9 Cylinder Connections	3	3-17 Disassembly	12
2-10 Operating Procedure	3	3-18 Inspection	12
2-15 Filling A Single High Pressure Cylinder	4	3-19 Reassembly	12
2-18 Filling High Pressure Cylinders Alternately	5	3-20 Test After Reassembly	12
2-25 Service Instructions	6	3-21 Crankcase Bearings	12
2-26 Lubrication	6	3-22 General	12
2-28 Periodic Inspection	9	3-23 Disassembly	12
2-29 Trouble Shooting	9	3-24 Inspection	12
III REPAIR INSTRUCTIONS	11	3-25 Reassembly	12
3-1 General Leak Testing	11	3-26 Test After Complete Reassembly of the Equipment	12
3-3 V-Belts	11	IV PARTS LIST	13
3-4 Adjustment	11	4-1 General	13
		4-2 Electric Parts	13
		4-3 Connection Piping	13
		4-4 Spare Parts	14-17
		V PROPERTIES OF CO₂	19

LIST OF ILLUSTRATIONS

NUMBER	PAGE	NUMBER	PAGE
2-1 Components and Controls	2	2-4 Compressor Assembly, Exploded View	8
2-2 Typical CO ₂ Cylinder Filling System Schematic	4	3-1 Flip Valve Assembly	10
2-3 Cylinder Filling Unit	6	3-2 1/2" Angle Valve Assembly	10
Details (Sheet 1 of 2)	6	3-3 Pressure Regulating Valve	10
2-4 Cylinder Filling Unit Details (Sheet 2 of 2)	7	4-1 Safety Disc Assembly	17
		5-1 Installation Suction & Discharge Valves	18

CARDOX®

Carbon Dioxide Cylinder Filling Unit

1-042-0050

SECTION I INTRODUCTION

GENERAL. This manual contains the operating and maintenance instructions for the Cardox Cylinder Filling Unit, Cardox Stock Number 1-042-0050. A complete illustrated parts list is given at the back of the manual. The cylinder filling unit is used in the transfer of liquid carbon dioxide from a Cardox Low Pressure Storage Unit to carbon dioxide cylinders.

1-2. DESCRIPTION OF THE CYLINDER FILLING UNIT. The unit is a transfer pump fitted with operating controls, that is designed to receive liquid carbon dioxide at an inlet pressure of 200-300 pounds per square inch (psi), and deliver it into portable cylinders at a regulated pressure ranging from 600 psi to 1000 psi, as needed. The cylinder filling unit includes the equipment listed below.

COMPRESSOR - Single stage single cylinder transfer pump with automatic valves. This unit is intended for handling liquid carbon dioxide only.

DRIVE MOTOR - A five horsepower electric motor is furnished. The standard motor is a 220/440 volt 50/60 cycle three-phase item; however, any motor meeting special requirements may be used. The data plate on the motor will identify special characteristics, if any are specified.

MOTOR SWITCH - This is a commercial ON-OFF pushbutton switch which includes the motor thermal overload devices.

PRESSURE REGULATOR - This is a ball type relief valve, arranged to both regulate filling pressure, and return excess carbon dioxide to the storage tank. In filling a number of cylinders, each requiring the same filling pressure, the operator sets the pressure once, then turns the valve ON and OFF by a full throw of the handle for each cylinder. In OFF position (up), pump liquid is returned to the storage tank at low pressure, so the unit need not be shut down between fillings of cylinders.

PRESSURE GAUGE - This gauge indicates delivery pressure to a filling cylinder.

BLEEDOFF VALVES - These hand operated valves are used to relieve pressure in certain lines when those lines are to be disconnected.

RELIEF VALVES AND SAFETY DISC - Two relief valves and a safety disc are installed in the system to protect those parts of the system in which liquid might be trapped by closed valves. The items listed above are supplied as part of the Cylinder Filling Unit. The following items, not part of the unit, are needed for installation and use of the unit.

TWO FLEXIBLE CHARGING HOSES - To connect the unit to the cylinders being filled.

PLATFORM SCALE - To indicate when FULL weight of cylinder is reached.

SUPPLY AND RETURN PIPING - To connect the cylinder filling unit to the user's storage unit.

TABLE OF LEADING PARTICULARS

Length	39 in
Width	21-1/2 in
Height	33-1/2 in
Weight	550 lbs
Power Source	220/440 volts, 50/60 cycle, 3 phase, or is specified by customer's order
Inlet Pressure	200-300 psi
Discharge Pressure (adjustable)	600-1000 psi
Capacity, pounds per minute	about 35 ¹⁰⁰⁰ _{psi}
Oil Capacity	1 1/2 pints
Maximum discharge pressure	1200 psig

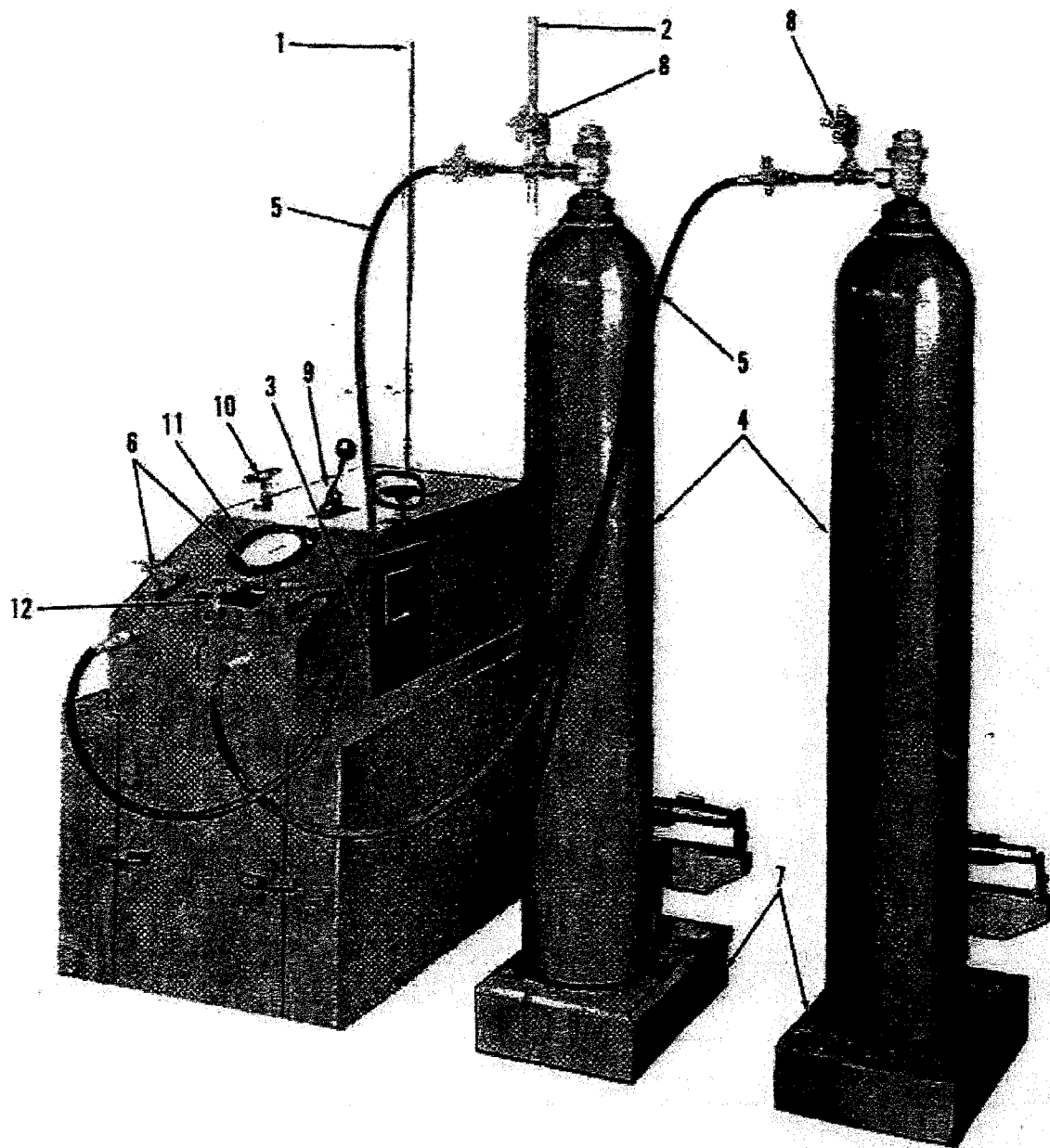

2011-1

- | | | |
|---------------------------------|----------------------------------|------------------------------|
| 1. Return Line (1/2" insulated) | 5. Flexible Charging Lines | 9. Pressure Regulating Valve |
| 2. Supply Line (1" insulated) | 6. Cylinder Filling Valves | 10. Vapor Return Valve |
| 3. Motor Switch | 7. Scale | 11. Pressure Gauge |
| 4. Cylinders | 8. Charging Line Bleedoff Valves | 12. Bleedoff Valve |

Figure 2-1. Components and Controls
1-042-0050W

SECTION II OPERATION AND SERVICE

2-1. INSTALLATION OF THE CYLINDER FILLING UNIT.

2-2 LOCATION. Select a site with a reasonably level floor, within 25 - 50 ft. of the carbon dioxide storage unit. The site must provide enough room for the operator to work when connecting cylinders, and must have electric power available for the motor.

2-3 UNPACKING. At the selected site, remove the shipping crate and protective wrappings. Fasten the unit to the floor with lag bolts through the four feet.

2.4 EQUIPMENT INSTALLATION

a) Location Locate the pump assembly on a solid surface as close to the CO₂ storage tank as practical. Bolt the unit securely to the floor through the four mounting feet. Connect an insulated 1" liquid supply line to the rear of the unit using a 3000 pound forged steel union. Connect an insulated 1/2" liquid return valve to the CO₂ storage tank. This line can return to the vapor side of the tank if necessary, but not recommended. (see fig. 2-1)

b) Piping The piping should be schedule 80 (heavy weight) carbon steel pipe with 2000 or 3000 pound forged steel fittings. These should be insulated with a minimum 1" thick insulation and adequately supported. Type K copper tubing and silver brazed fittings can be used, but are subject to vibration and pressure pulsation during operation. All valves should be brass or stainless steel and rated for a minimum 500 psig working pressure.

c) Electrical A customer supplied fused disconnect (15A 480V or 30A 240V) should be provided behind the unit in close proximity. Connect the power supply to meet all applicable codes and National Electrical Code (NEC) to the pump motor starter (3). The standard motor is rated for 240/480 V 3 phase 50/60 Hz operation. The motor winding connection needs to be checked to match the supply voltage. The unit is shipped with overloads for both 240 and 480 volts service.

2.5 OPERATING INSTRUCTIONS

2-6 CYLINDER PREPARATION. High pressure cylinders should be properly prepared prior to filling them with carbon dioxide. This preparation will vary with factors beyond the scope of this manual, and is to be determined by the policy and needs of the user.

2-7 GENERAL. The charging lines and valving used between the cylinder filling unit and the cylinders being filled may vary. Figure 2-2 illustrates the recommended valving on the charging lines.

WARNING

Each charging line must contain a shutoff valve and a bleedoff valve.

2-8 With two charging lines available, continuous cylinder filling is possible; as a filled cylinder is being replaced at one charging line, filling of a second cylinder can continue at the other charging line.

2-9 CYLINDER CONNECTIONS. Connect the cylinders to be filled as shown in figure 2-1, and place them on the scale, one at a time. Compare the weight indicated on the scale with the "empty" and "full" weights stamped on the cylinder to determine the amount of CO₂ remaining in it. The difference between the actual weight and "full" weight will indicate the amount of CO₂ remaining in it.

NOTE

Do not start the motor until the following steps have been completed to insure pressure on the piston head, and to avoid opening the relief valves or safety disc.

2-10. OPERATING PROCEDURE. Open the storage tank liquid valve(s) (18&20, figure 2-2). This will pressurize the pump (17) through the inlet valve, the pressure regulating valve (9), the cylinder filling valves (6) and bleedoff valve (12).

2-11. With the handle of the pressure regulating valve (9, figure 2-1) raised, open the return valve(s), to the storage unit, and open the storage tank vapor valve (10,19 figure 2-2). All carbon dioxide circulated through the pump will now return to the storage tank until the regulator valve handle is lowered and a pressure adjustment is made. The entire cylinder filling unit is now at storage tank pressure.

2-12. Open bleedoff valve (12) to purge vapor, until carbon dioxide snow is discharged, then close the valve. Press the motor START button (3, figure 2-1), operating the pump until frost has formed on the return line (1) and on the pump cylinder head.

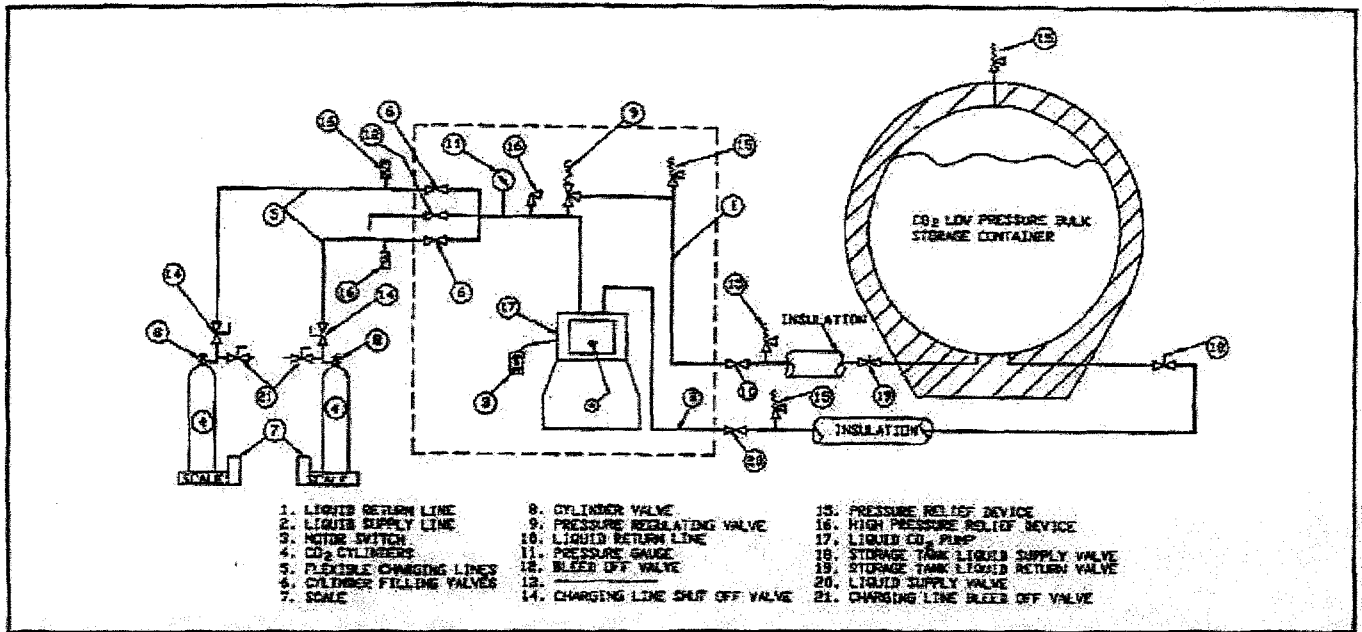

Fig. 2.2 Typical CO₂ Cylinder Filling System Schematic

2-13 Move the regulator handle to the horizontal position (push down), and with an Allen wrench inserted in the socket head set screw at the top of the regulator, adjust the charging pressure, indicated on the pressure gauge, (11). Cold cylinders will fill readily at 600 to 800 pounds pressure; however, warm cylinders require higher pressures, ranging from 800 to 1000 pressure.

2-14 Should a vapor lock form (indicated by a defrosting of the piping on the discharge side of the compressor), fully open the pressure regulating valve (9) by raising the handle. Allow carbon dioxide to bypass back into the storage until a frost coating reappears on the piping and then proceed to readjust the pressure regulating valve to proper charging pressure as indicated in paragraph 2-13. At certain temperatures and pressures there will be a pressure regulating valve noise. It will not however, affect the operation of the equipment.

2-15. FILLING A SINGLE HIGH PRESSURE CYLINDER. Open the appropriate cylinder filling valve (6, figure 2-2), charging line shutoff valve (14) and cylinder valve (8).

NOTE

As the empty cylinder starts filling, the charging pressure indicated on the pressure gage will decrease initially, and then increase as filling proceeds.

cylinder until the "full" weight stamped on the cylinder is reached, as indicated on the scale (7).

CAUTION

Do not overfill the high pressure cylinders. If a cylinder is overfilled, bleed off the excess carbon dioxide so that the safety disc on the cylinder will not rupture.

2-17. When the cylinder is full, shut down the equipment as follows:

- a. Close the cylinder valve (3).
- b. Close the cylinder filling valve (6).
- c. Bleed the carbon dioxide trapped in the flexible charging line (5) by opening the charging line bleedoff valve (13) and then disconnect the cylinder.

WARNING

Liquid carbon dioxide trapped in the flexible charging line between the two valves might reach extreme pressures if the line is not depressurized at once. Never discharge or bleed off carbon dioxide through the flexible charging lines unless they are connected to cylinders or firmly secured. A flexible charging line will whip around if not firmly secured and may cause personal injury.

2-16. Allow the carbon dioxide to fill the high pressure

d. Fully open the pressure-regulating valve (9) (raise the lever handle) and then stop the electric motor by pressing the STOP button on the motor switch. (3)

e. Close the liquid supply valve (20).

f. When the return line (1) has defrosted, close the storage tank liquid return valve (10).

g. Bleed the carbon dioxide from the cylinder filling unit assembly and interconnecting piping from the liquid storage tank by opening the bleedoff valve (12). Close all bleedoff valves to exclude moisture from the system.

h. The return valve (8) may, if desired, be closed at this time. This operation is not necessary if the liquid storage tank is used only as a carbon dioxide supply for the cylinder filling unit assembly.

2-18. FILLING HIGH PRESSURE CYLINDERS ALTERNATELY. If cylinders of the same size are being filled alternately, one cylinder filling valve connection (6) is open for filling while the other cylinder filling valve connection is closed. This allows the second cylinder to be moved into position and connected to the charging lines.

CAUTION

Do not allow the equipment to idle at charging pressure for long periods of time. This will cause pressure buildup within the storage tank and excessive wear to the cylinder filling unit.

2-19. See figure 2-2 for reference to cylinders A, B, and C discussed in the following paragraphs. The following procedure should be adhered to when filling cylinders alternately. With cylinders A and B attached to the flexible charging lines and the operating instructions in paragraphs 2-10 through 2-14 performed, open the cylinder filling valve (6), charging line shutoff valve (14) and cylinder valve (3) to cylinder A.

NOTE

As the empty cylinder starts filling, the charging pressure gauge (11) will decrease initially and gradually increase as filling proceeds.

2-20. Allow the carbon dioxide to fill cylinder A until the "full" weight is indicated on the scale (7).

CAUTION

Do not overfill the cylinders. If a cylinder is overfilled, the excess carbon dioxide must be bled off so that the safety disc on the cylinder will not rupture.

2-21. When cylinder A is full, perform the following steps:

a. Close the cylinder valve (3) on cylinder (A).

b. Open the cylinder valve (6), charging line shutoff valve (14) and cylinder valve (3) to cylinder (3) to cylinder B. This will not permit charging of empty cylinder B while filled cylinder A is being removed and empty cylinder C is being connected to the charging line.

c. Close charging line shutoff valve (14) to cylinder A and crack bleedoff valve (13).

d. Remove filled cylinder A and replace with empty cylinder C, connecting it to the flexible charging line. Close bleedoff valve (13).

e. When cylinder B is filled, repeat steps a. through d. for cylinder B and additional empty cylinders.

2-22. After all cylinders have been filled and the last cylinder removed from the flexible charging line, close both cylinder filling valves (6).

2-23. Perform procedural steps 2-17d through 2-17g to completely shut down the equipment after all filling has been completed for the day.

2-24. Figure 2-3 illustrates the appearance and location of the components referenced in the preceding operational text to figure 2-2.

2-25. SERVICE INSTRUCTIONS.

2-26. LUBRICATION. The equipment requires no lubrication other than maintaining the oil level in the compressor crankcase. When the equipment is in frequent operation, check the oil level at least twice a week and change the oil at least every three months. To check the oil level, remove the oil level plug (53, figure 2-4). The oil is at the proper level when it is even with the bottom of the oil level hole. If the oil level is low, fill to the proper level with good SAE 30 motor oil. High detergent oil is not needed, but may be used.

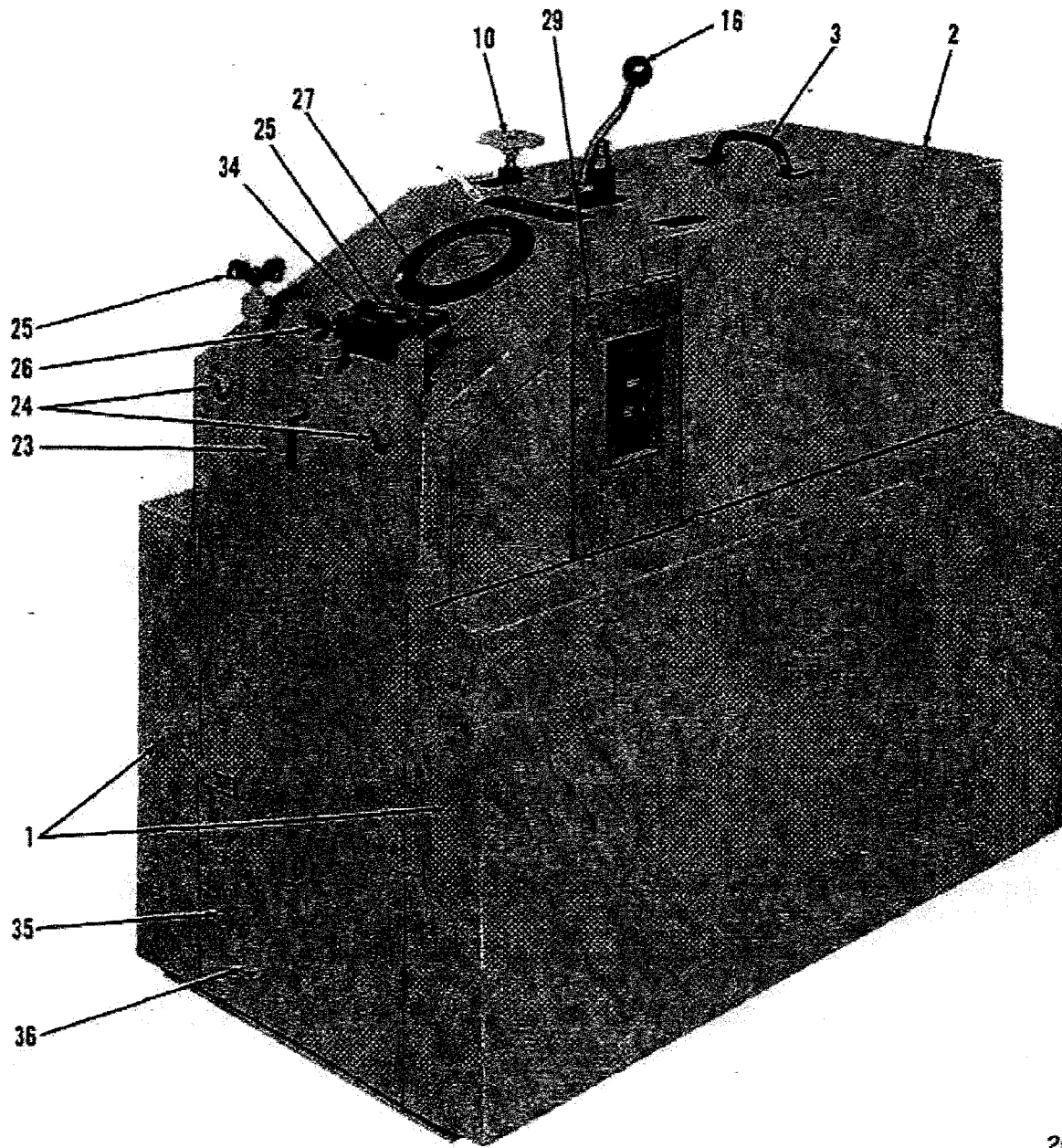

2011-3

- | | | |
|-----------------|----------------------|-------------------------------|
| 1. Housing Side | 7. U Bolt | 13. U Bolt |
| 2. Cover | 8. Return Pipe | 14. Nipple |
| 3. Handle | 9. Relief Valve | 15. Safety Disc |
| 4. Union | 10. Return Valve | 16. Pressure Regulating Valve |
| 5. Nipple | 11. Discharge Piping | 17. Nipple |
| 6. _____ | 12. Street Elbow | 18. Pipe Cross |

Figure 2-3. Cylinder Filling Unit Details (Sheet 1 of 2)

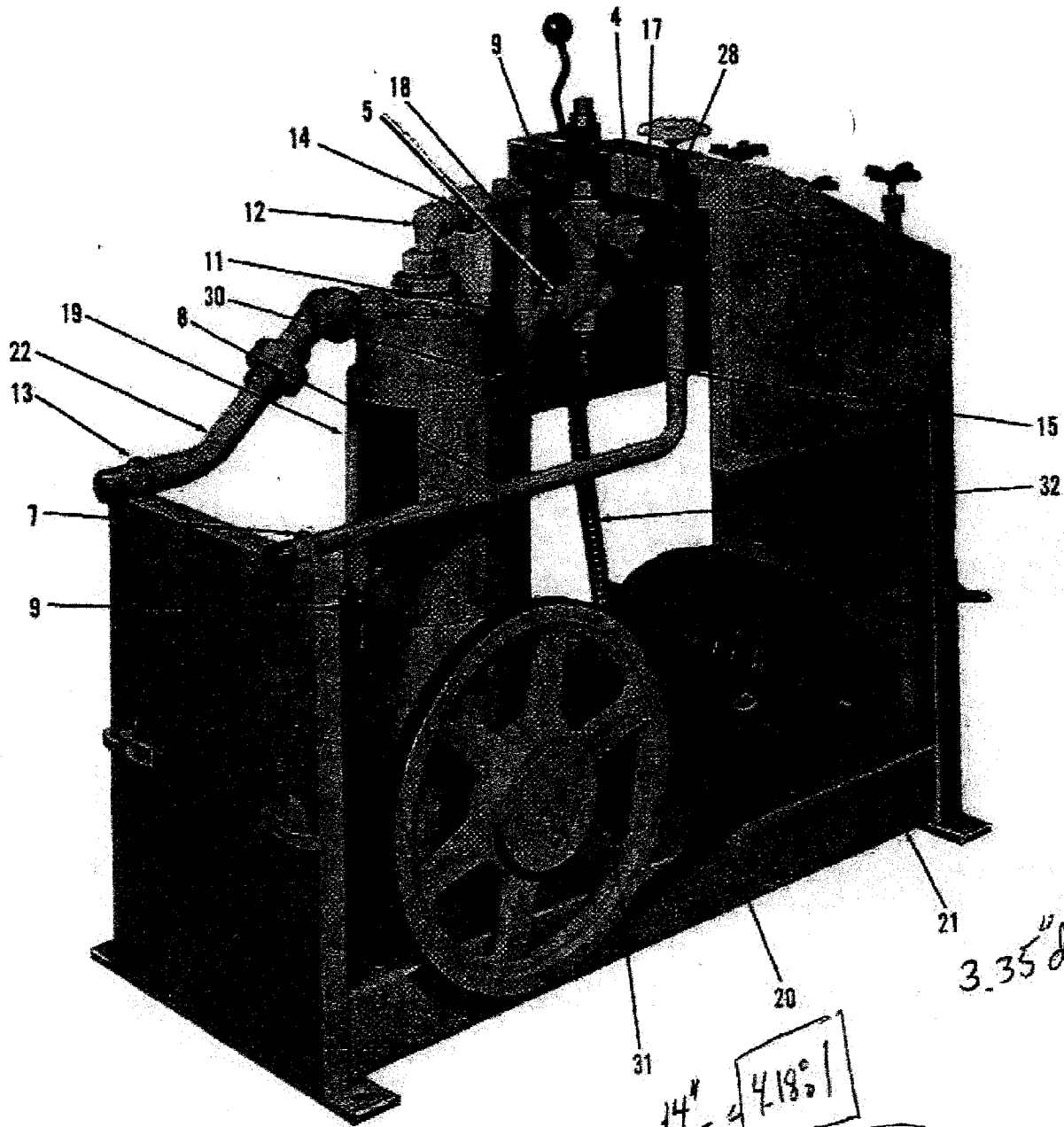

- | | | |
|---------------------------------------|--------------------------|----------------------------|
| 19. Cardox CO ₂ Compressor | 25. 1/2 inch Valve | 31. Cable Connector |
| 20. V Belt Set | 26. 1/4 inch Valve | 32. Flexible Cable |
| 21. Sheave | 27. Pressure Gauge | 33. _____ |
| 22. Suction Piping Assembly | 28. Manifold | 34. Nameplate |
| 23. Bent Pipe | 29. Start-Stop Switch | 35. Base |
| 24. Reducer Bushing | 30. Cable Connector (90) | 36. Motor Adjustment Screw |

Figure 2-3. Cylinder Filling Unit Details (Sheet 2 of 2)

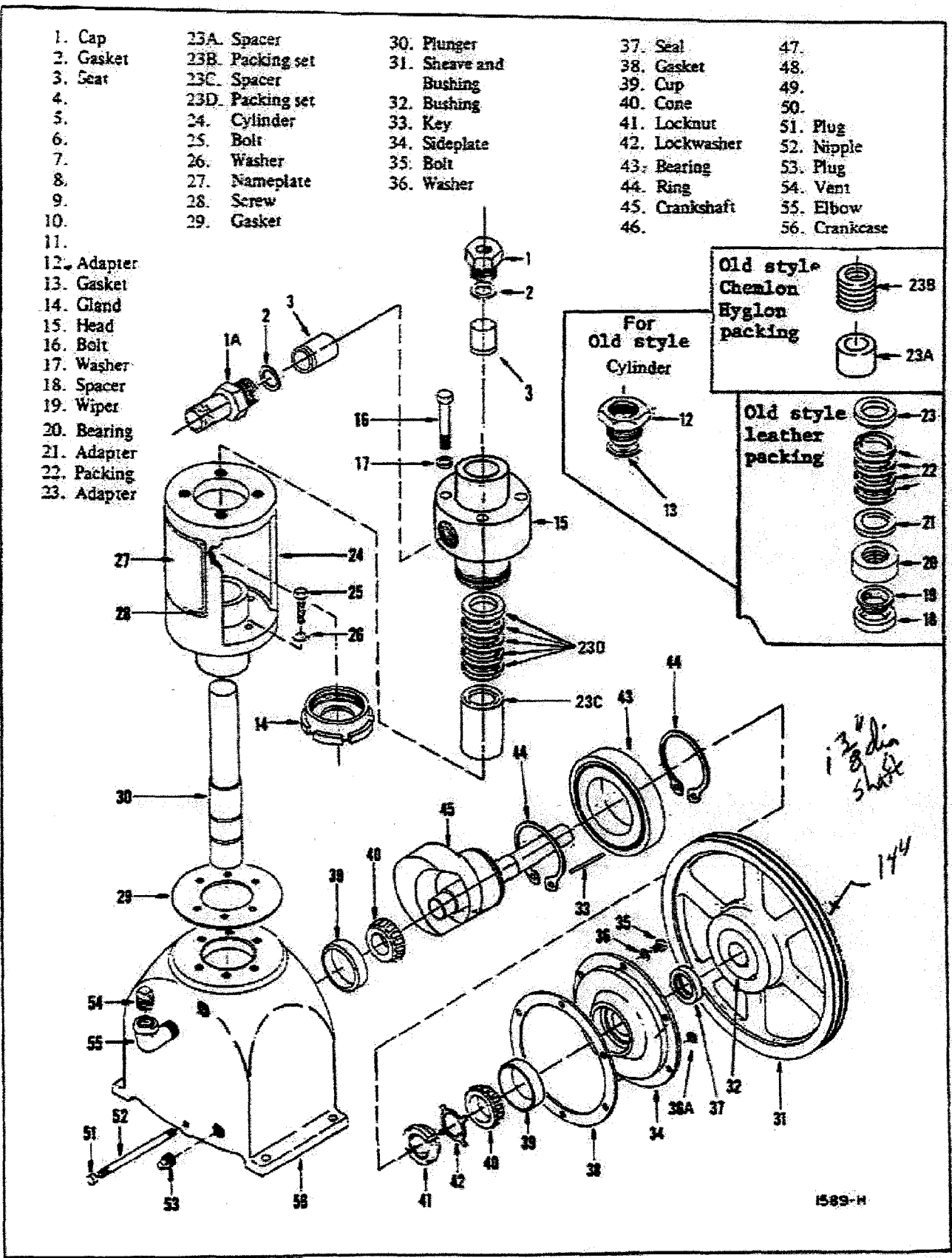

1589-H

Figure 2-4. Compressor Assembly - Exploded View

2-27. To drain the crankcase oil, remove oil drain plug (51). Replace plug when the crankcase has been thoroughly drained. Remove filler vent (54) and oil level plug (53). Fill the crankcase with proper oil through the filler vent hole until oil begins to run out through the oil level plug hole. Replace the filler vent and oil level plugs. Crankcase capacity is approximately one and one-half pints.

2-28. PERIODIC INSPECTION. No definite periodic inspection or preventive maintenance schedule is

established for the cylinder filling unit assembly other than periodic lubrication. Any trouble that may arise will be observed while the equipment is in operation.

2-29. TROUBLE SHOOTING. Table 2-1 is tabulated for ease in locating possible troubles, their probable cause and remedy. The remedy column references applicable paragraphs when detailed maintenance procedures are required.

TABLE 2-1.TROUBLE SHOOTING

TROUBLE	PROBABLE CAUSE	REMEDY
Low Capacity	<p>Cylinder filling valves not fully open .</p> <p>Pressure regulating valve pressure setting low.</p> <p>Pressure regulating valve cannot be adjusted to maintain charging pressure.</p> <p>V-belts broken or slipping.</p> <p>Excessive leakage through pump packing around plunger.</p> <p>Pump valve gaskets (2,11 or 13, figure 2-4) leaking.</p> <p>Pump valves not operating properly.</p> <p>Safety relief valves leaking.</p>	<p>Open liquid supply valves.</p> <p>Adjust valve until pressure gauge indicates proper charging pressure.</p> <p>Worn valve ball or seat. See paragraph 3-8c.</p> <p>Readjust belt tension or replace if necessary. See paragraphs 3-4 and 3-5.</p> <p>Tighten packing gland. If leakage persists, replace packing set. See paragraphs 3-16 through 3-20.</p> <p>Tighten caps (1, figure 2-4) or adapter (12) as required or replace gaskets if damaged.</p> <p>Clean valves and valve seats. Replace if worn or damaged. See paragraphs 3-12 through 3-14. (Fig. 2-5)</p> <p>Replace valve or disc assembly.</p>
Pump valve blocked. Freeze up.	Excessive moisture in carbon dioxide supply, or foreign particles in valve.	Remove, clean and dry valve. Add a strainer in the liquid supply line if trouble continues.
Piston Too Hot.	Piston Packing gland too tight.	Loosen packing gland; replace packing or packing set if worn. See paragraphs 3-16 through 3-20.
Compressor knocking.	<p>Oil level low.</p> <p>Damaged crankcase bearings.</p> <p>Worn cylinder.</p>	<p>Add oil.</p> <p>Replace bearings. See paragraphs 3-22 through 3-25.</p> <p>Replace (See 2.4 - 24)</p>

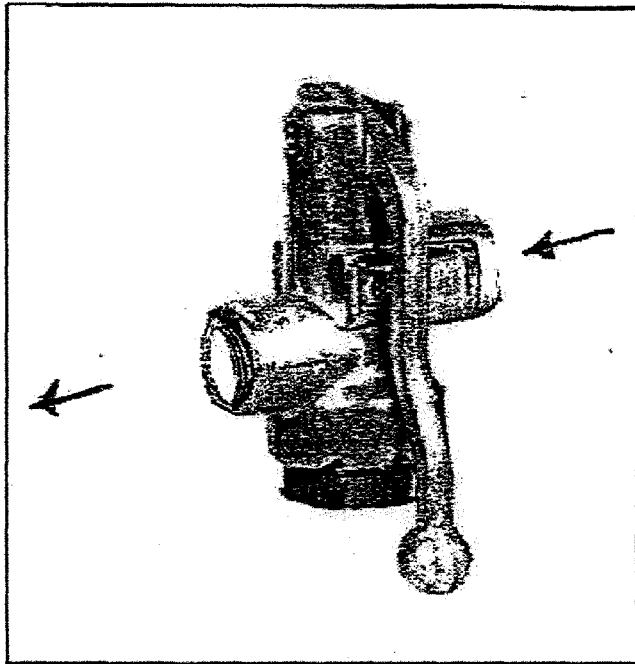

Fig. 3-1. Flip Valve Assembly

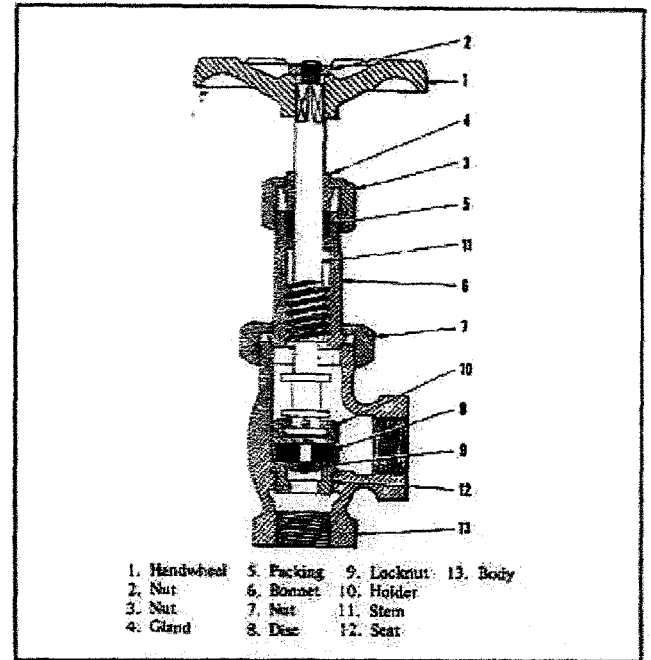

Fig. 3-2. 1/2 Inch Angle Valve Assembly (Return Valve)

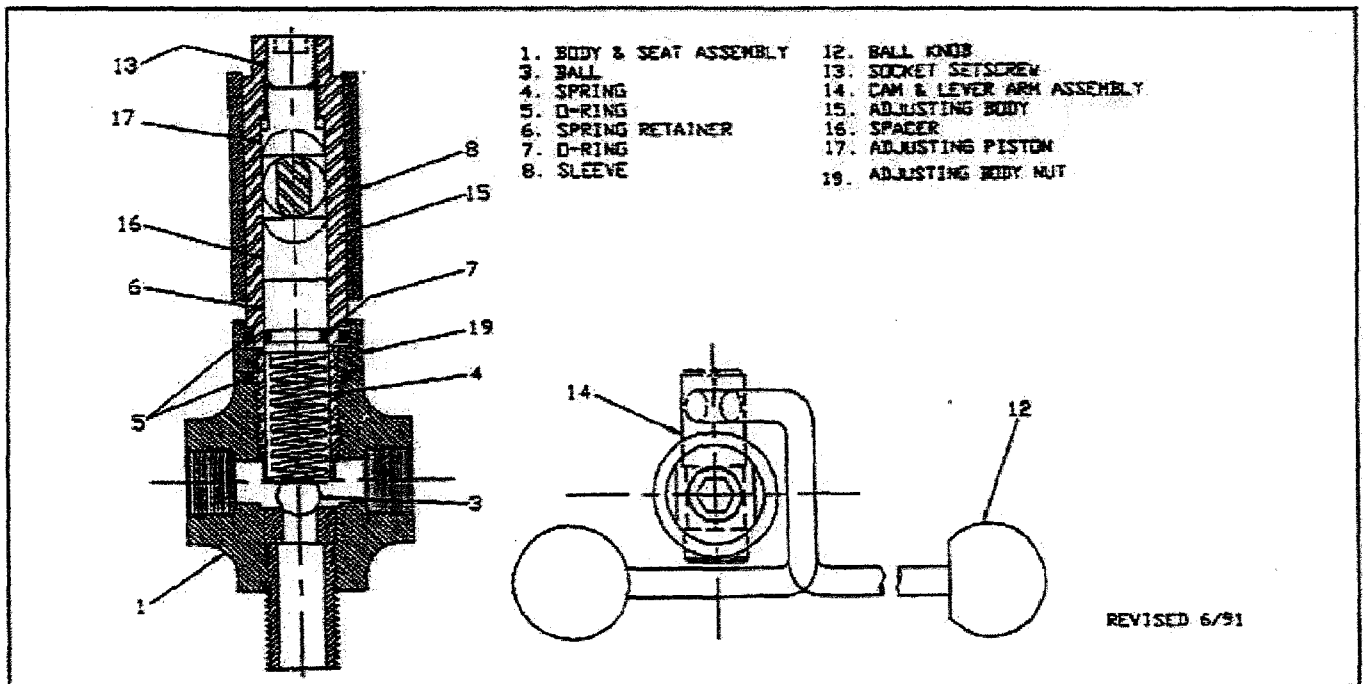

Figure 3-3. Pressure Regulating Valve

SECTION III REPAIR INSTRUCTIONS

3-1. **GENERAL LEAK TESTING.** After maintenance has been performed on any pressurized components removed from the system, test the connections with soapsuds when the equipment is operated to check for leakage. Leakage is usually detected by a hissing noise and the appearance of a white fog similar to snow. Small leaks are neither audible or visible.

3-2. To detect small leaks, make a mixture of soap and water. The suds produced should be of a fluffy texture rather than a creamy mixture. Apply the soapsuds to the connections, being certain the suds cover all parts of the connection under test at the same time. Gradual enlargement of the bubbles indicates a carbon dioxide leak. Allow approximately one minute for each test. If no bubbles form in that time, it can be assumed the joint is not leaking.

3-3. **V-BELTS.**

3-4. **ADJUSTMENT.** Loosen the motor mounts and adjust the V-belt tension so that no slipping occurs, by moving the electric motor on its base with the motor adjustment screw (36, figure 2-3) as required. The belts should be just tight enough to prevent slipping. Deflection of each belt when exerting firm thumb pressure should not exceed one and one-half inches.

3-5. **ALIGNMENT.** Check alignment of the electric motor pulley and compressor pulley with a straight edge against the pulley faces. Adjust the pulleys as required by loosening the bushing setscrews and moving the pulleys in or out. The V-belt should run parallel to the straight edge and the pulleys should be in alignment. Belts showing signs of wear or deterioration should be replaced as a matched set.

3-6. **VALVES.**

3-7. **GENERAL.** Valve maintenance is generally limited to tightening the stem packing nuts or replacement of stem packing to stop leakage of carbon dioxide around the valve stem. If leakage around the stem cannot be stopped by either of the previously described procedures, replace the valve as an assembly.

WARNING

Before servicing valves, be certain all carbon dioxide has been bled from the cylinder filling unit assembly.

3-8. **VALVE REPAIRS**

a. 1/4 Inch and 1/2 Inch Barstock Valves (Bleedoff and Cylinder Filling Valves, see figure 3-1). If leakage cannot be controlled by completely closing the valve, replace the complete valve.

b. 1/2 Inch Angle Valve. If leakage cannot be controlled by completely closing the valve, disassemble by following the key index numbers and replace the neoprene disc (8). If leakage persists, replace the complete valve.

c. Pressure Regulating Valve (see figure 3-3). If regulation of charging pressure cannot be maintained, disassemble the valve in the order of the index numbers, and check the ball (3), spring (4) and seat (2) for wear or damage. Replace any parts found to be defective.

d. Safety Relief Valves and Safety Disc. No maintenance is to be performed on the safety relief valves (9, figure 2-3) or safety disc (15). The two safety relief valves are preset to relieve pressure in excess of 450 pounds per square inch trapped in the supply line, return line and the piping between the pump and cylinder filling valves. They should seal completely when the pressure drops below 450 pounds per square inch. Depressurize the complete cylinder filling unit and replace the defective valve as a complete assembly. The safety disc is a pressure relieving device set to rupture at 1200-1500 pounds per square inch. This device protects the pump when it is running. If the disc ruptures, depressurize the complete cylinder filling unit and replace the disc.

3-9. **PUMP ASSEMBLY.** (See figure 2-4)

3-10. **GENERAL.** Loss of capacity (excessive time required to fill a cylinder) is usually due to faulty operation or obstructions in the valves (1 through 10). A fifty pound cylinder should take approximately one and one-half minutes to fill under average operating conditions. If no excessive leakage is observed past the piston packing gland (14), the valves should be removed and inspected.

3-11. **CHECK VALVES.**

3-12. **DISASSEMBLY.** Remove the valves as an assembly. If it is determined the valves are damaged, they must be replaced as assemblies.

3-13. **INSPECTION.** Inspect the valves to determine that they seat properly and that the faces are not worn or

pitted. Remove all obstructions that may prevent the valves from seating properly.

NOTE

Inspect the valves for moisture. Valves must be thoroughly dry before they are reassembled.

3-15. REASSEMBLY. Replace the entire valve assembly, if damaged, using new valve cap gaskets (2 and 11). Be sure that the gaskets are in straight so that they do not leak or obstruct the valve opening.

3-15. PISTON PACKING GLAND.

3-16. GENERAL. Heavy discharges of carbon dioxide snow around the piston indicates excessive leakage past the packing. Tighten the packing gland (14) to stop excessive leakage. If the leakage persists, proceed as indicated in following paragraphs.

3-17. DISASSEMBLY. Disassemble the packing from the piston head by first removing the packing gland nut (14) and then the head as an assembly (1 through 25 excluding 14). Follow the order of key index numbers assigned to the exploded view illustration when removing the packing from the head.

3-18. INSPECTION. Cylinder filling unit assembly Model 1-042-0050 Serial Numbers 199 and up and Pump Model FS-21561-G2 Serial Numbers 2607 and up, inspect spacer (23A), packing set (23B) for wear or damage. Packing set (23B) should be replaced whenever excessive leakage is noted. For cylinder filling unit assemblies Model 1-042-0050 Serial Numbers 199 and Pump Models FS-21561-G2 Serial Numbers 2607 and lower, inspect spacer (18), wiper (19), bearing (20), adaptor (21), packing (22) and adapter (23) for wear or damage. Inspect plunger (30) for scratches, gouges or excessive scoring. Replace all damaged parts.

Check the cylinder (24) for excessive wear and replace if required. The plunger (30) should have very little side to side movement when placed in the cylinder. (less than 1/8").

3-19. REASSEMBLY. Reassemble the items removed from the piston in the reverse order of disassembly. The packing must be inserted one at a time. The sequence must not change. Reassemble the head as an assembly and tighten down the bolts (16) evenly to properly align the head. Tighten the packing gland (14) by hand. When breaking in new packing, pressurize and

operate the equipment to determine that the plunger (30) is not misaligned and is not leaking. If the packing is too tight or the head is misaligned when reassembled, overheating and wear will result.

3-20. TEST AFTER REASSEMBLY. Frost should always be maintained around the cylinder head packing during operation. If leakage is observed with a new packing, the packing gland (14) is too loose and should be tightened. The packing gland is properly adjusted when only a slight amount of vapor or no visible vapor is discharged around the packing.

Slight carbon dioxide leakage past the packing cools the piston for more efficient operation.

3-21. CRANKCASE BEARINGS.

3-22. GENERAL. Parts in the compressor crankcase should not be removed unless excessive vibration and knocking cannot be eliminated by adding oil to the crankcase or tightening the pulley.

3-23. DISASSEMBLY. If excessive vibration and knocking cannot be eliminated by performing the previously described operations, disassemble the pulley and all other parts from the crankcase (56), bearing cups (39) by following the sequence of key index numbers assigned to the exploded view illustration. Use a bearing puller or arbor press to remove the bearing cones (40) and cam bearing (43) from the crankshaft (50).

3-24. INSPECTION. Inspect all parts visually for excessive wear or damage inspect the cups (39) and cones (40) and look for galling, pitting, scoring, fractures or abraded surfaces. Bearing (43) will generally be the cause of vibration or knocking if damaged. Discoloration of rollers or rings indicates insufficient oil supply. Check the cylinder (24) for excessive wear. If the bore is egg shaped and allows more than plus or minus 1/16 inch lateral movement, it should be replaced. Replace all damaged parts.

3-25. REASSEMBLY. Reassemble in the reverse order of disassembly. During reassembly, use a new oil seal (37), gasket (38) and lockwasher (12).

3-26. TEST AFTER COMPLETE REASSEMBLY OF THE EQUIPMENT. After the equipment has been reassembled, all piping connections that have been disassembled should be tested as instructed in paragraphs 3-1 and 3-2 for carbon dioxide leakage. An operational test will determine if the equipment is up to the proper standard.

FURTHER TECHNICAL INFORMATION

The following publications should be consulted for further information on Carbon Dioxide and Carbon Dioxide Cylinder filling.

G 6.0 **Carbon Dioxide**

G 6.3 **Carbon Dioxide Cylinder Filling and Handling Procedures**

Compressed Gas Association

1725 Jefferson Davis Hwy.

Arlington, VA 22202

(703) 412-0900

*4221 Walnut Rd 5th Floor
Chantilly Va 20151
703-788-2700
703-934-1831 Fax
www.cganet.com*

SECTION IV

PARTS LIST

4-1. **GENERAL.** All parts listed in this section, except those listed as NS (not stocked) in the Part Number column can be ordered from **Air Liquide America Corporation** by giving the part number. Parts bearing the indication NS are not sold separately. If any of these parts is needed, order the next higher assembly with which it is associated.

4-2. **ELECTRICAL PARTS.** Since original motors, switches and overload heaters are specified by the user according to his power source characteristics, only the most frequently ordered are listed for these parts. Replacements

for these items in rating values not listed can be ordered by the part description and electrical rating.

4-3. **CONNECTION PIPING.** Connection piping is not listed, since these depend on the individual installation.

4-4. **SPARE PARTS.** Air Liquide recommends that each user of a cylinder filling unit keep at least a small stock of certain spare parts on hand. These parts are identified by (S) in the Units Per Assembly column of the parts listing.

FIGURE & INDEX NO.	PART NO.	DESCRIPTION	UNIT PER ASSY
2-3-	1-042-0050W	CYLINDER FILLING UNIT ASSEMBLY	1
-1	3-071-0029	SIDE, Housing	2
-2	3-071-0027	COVER ASSEMBLY	1
-3	6-029-0061	HANDLE	1
	6-005-0664	SCREW, Machine	3
	6-007-0093	NUT	3
	6-008-0073	WASHER	4
-4	5-039-0243	UNION, Female, 2000 psi, 1/2 in.	2
-5	5-040-0028	NIPPLE, Pipe, Heavy weight, 1/2" dia x 1 1/2" lg.	1
-7	7-005-0005	BOLT, U	1
	6-007-0030	NUT (for U-bolt #7 & #13)	4
	6-008-0024	WASHER (for U-bolt #7 & 13)	4
-8	3-942-0321	PIPE, Return	1
-9	1-061-0753	VALVE, Safety relief, 450 psi	2
-10	1-061-0168	Valve Assembly, Globe, Angle Type	1
-11	3-071-0013	DISCHARGE PIPING ASSEMBLY	1
-12	5-039-0135	ELBOW, Street 3000# F.S., 1/2 IN.	1
-13	7-005-0007	BOLT, U	1
-14	5-040-0029	NIPPLE, Pipe, heavy weight, 1/2" dia x 2" lg.	1
-15	2-063-0002	DISC ASSEMBLY, Safety	1
-16	1-061-0713	VALVE ASSEMBLY, Relief, pressure regulating	1
-17	5-040-0028	NIPPLE, Pipe, heavy weight, 1/2" dia. x 1 1/2" lg.	1
-18	5-039-0090	CROSS, screwed, 3000# F.S., 1/2 in.	1
-19	1-071-0023	Pump Assembly Carbon Dioxide	1
	6-005-0489	SCREW, Hexagon socket head, 1/2 - 13 x 2 in. lg plated steel	4
	6-008-0078	WASHER	4
-20	5-004-0116	BELT, V. MATCHED SET	1(s)
-21	7-004-0007	SHEAVE, 2 groove, 3.35 in. O.D.	1
	7-004-0010	BUSHING	1
	6-008-0134	KEY, Square, 1/4 square x 2 in.	1
-22	3-071-0012	SUCTION PIPING ASSEMBLY	1
-23	5-049-0552	PIPE, Bent	1
-24	5-039-0003	BUSHING, Hexagon reducer, 1/4 X 1/2 in. forged steel, 6000 psi	2
-25	1-061-0017	VALVE ASSEMBLY, Barstock 1/2 IN.	2
-26	1-061-0015	VALVE ASSEMBLY, Barstock 1/4 IN.	1
-27	7-024-0008	GAUGE, Pressure 3-1/2 in., 0-2000 psi	1
-27a	3-042-0065	ADAPTER PLATE - 4 1/2 to 3 1/2 in dia gauge	1
-28	3-042-0058	MANIFOLD ASSEMBLY, Welded	1
-29	5-017-0239	SWITCH ASSEMBLY, Manual starting size 1, 240/480 volt alternating current 3 phase, 60 cycle	1
	6-006-0192	SCREW	3
	6-007-0093	NUT	3
	6-008-0073	WASHER	3
	7-016-0008	HEATER ELEMENT, 240 volt 3 phase 60Hz	3
	7-016-0012	HEATER ELEMENT, 480 volt 3 phase 60Hz	3
-30	5-012-0038	CONNECTOR, Flexible cable, 1/2 in. x 90°	1
-31	5-012-0037	CONNECTOR, Flexible cable, 1/2 in.	1

FIGURE & INDEX NO.	PART NO.	DESCRIPTION	UNIT PER ASSY.
-32	5-021-0014	CABLE, Flexible metal, 1/2 in. x 12 in. lg.	1
-33		MOTOR ASSEMBLY, Electric 184 T Frame 5 horsepower	
	6-007-0054	NUT	4
	6-008-0020	WASHER	4
-34	8-936-1000	NAMEPLATE	1
	6-006-0307	SCREW	4
-35	3-071-0030	BASE ASSEMBLY, Welded	1
-36	5-071-0246	SCREW, Motor adjustment	1
	6-008-0153	WASHER	1
2-4	1-071-0023	PUMP ASSEMBLY, Carbon dioxide	
-1	5-071-0028	CAP, Valve (Discharge)	1
-1A	3-042-0044	CAP, Valve (Suction)	1
-2	4-071-0004	GASKET, Valve - Use with #3	2(S)
-3	3-071-0034	VALVE ASSBY, Suction & Discharge(see fig. 5-1)	2(S)
-12	5-071-0158	ADAPTER, Plug, cylinder head (Old Style)	1
-13	5-023-0246	GASKET, Plug, cylinder head (Old Style)	1
-14	5-071-0111	GLAND NUT, Packing	1
-15	5-071-0107	HEAD, Cylinder	1
-16	6-005-0510	BOLT	4
-17	6-008-0124	WASHER	4
-18	5-071-0159	SPACER (Leather)	1
-19	5-071-0163	WIPER, Cylinder head (leather packing)	1
-20	5-071-0162	BEARING, Graphite (leather packing)	1
-21	5-071-0158	ADAPTER, Bottom (leather packing)	1
-22	5-023-0304	PACKING, Leather	1
-23	5-071-0157	ADAPTER, Top (leather packing)	1
-23A	3-071-0056	SPACER, Packing (obsolete)	1
-23B	7-023-0231	PACKING SET, Hyglon, 8 rings (obsolete)	1
	4-042-0015	PACKING KIT ASSEMBLY (spacer & packing set obsolete)	1
-23C	3-008-0011	SPACER, Packing (4 rings)	1
-23D	7-023-0616	PACKING SET, Hyglon, 4 rings	1(S)
-24	5-071-0117	CYLINDER	1
-25	6-005-0430	BOLT, Hexagon head, 3/8 - 16 x 1 3/4 in. lg. plated steel	6
	6-008-0020	WASHER	6
-27	8-936-1003	NAMEPLATE	1
-28	6-006-0307	SCREW	4
-29	5-023-0247	GASKET, Cylinder	1
-30	5-071-0123	PLUNGER	1
-31	7-004-0005	SHEAVE, 2 groove, 3V, 14 in. O.D.	1
-32	7-004-0006	BUSHING, Taper lock, 1-3/8 in. bore, 5/16 x 5/32 in. keyseat	1
-33	6-008-0300	KEY, Square, 5/16 x 5/16 x 1-3/4 in lg. steel	1
-34	5-071-0113	SIDEPLATE, Bearing	1
-35	6-005-0400	BOLT	6
-36	6-008-0075	LOCKWASHER	6
-36A	6-008-0355	WASHER, Sealing	1
-37	5-023-0300	SEAL, Oil	1
-38	5-023-0245	GASKET, Bearing sideplate	1

FIGURE & INDEX NO.	PART NO.	DESCRIPTION	UNIT PER ASSY.
2-4- 39-40	5-071-0101	CUP, Roller bearing; CONE, Roller bearing (set)	2
-41	5-071-0102	LOCKNUT	1
-42	5-071-0103	LOCKWASHER	1
-43	5-071-0105	BEARING, Roller	1
-44	5-071-0099	RING, Retaining	2
-45	5-071-0187	CRANKSHAFT ASSEMBLY	1
-51	5-039-0322	PLUG, Pipe, 1/4 in., 150 psi malleable iron	1
-52	5-040-0567	NIPPLE, Pipe, 1/4 dia x 7 in. lg. galvanized iron	1
-53	5-039-0148	PLUG, Pipe, square head, 1/8 in. galvanized iron	1
-54	5-039-0068	VENT, Plug	1
-55	5-039-0448	ELBOW, Street, 1/2 in., 150 psi galvanized iron	1
-58	5-071-0186	CRANKCASE	1
3-1-	1-061-0015	VALVE ASSEMBLY, Barstock, 1/4 in.	1
3-2-	1-061-0168	VALVE ASSEMBLY, Globe, Angle Type	1
3-3-	1-061-0713	VALVE ASSEMBLY, relief pressure regulating	
-1	2-061-0037	BODY & SEAT ASSEMBLY	1(S)
-3	5-061-0611	BALL	1
-4	5-047-0129	SPRING	1
-5	5-023-0533	O-RING	2(S)
-6	3-061-0127	RETAINER, Spring	1
-7	5-023-0462	O-RING	1(S)
-8	3-061-0130	SLEEVE	1
-9			
-10			
-11			
-12	5-029-0001	KNOB, BALL	1
-13	6-005-0753	SETSCREW, Socket	1
-14	3-961-0106	CAM & ARM, LEVER ASSEMBLY WELDED	1(S)
-15	3-961-0105	ADJUSTING BODY	1
-16	3-061-0128	SPACER	1(S)
-17	3-061-0132	PISTON, Adjusting	1(S)
-18			
-19	3-961-0107	NUT, ADJUSTING BODY	1(S)
	4-961-0021	KIT CONVERSION, New style adjusting body	
4-1-	2-063-0002	DISC ASSEMBLY, Safety	
-1	3-063-0008	NUT, Disc	1
-2	7-063-0002	DISC, Safety	1(S)
-3	7-023-0040	WASHER, Fiber	1(S)
-4	3-039-0009	CONNECTOR, Double male	1
		<u>CYLINDER FILLING ACCESSORIES</u>	
	<u>HOSE ASSEMBLIES</u>		
	1-026-0237	HOSE ASSEMBLY, CO ₂ CYLINDER FILLING 1/4" X 6' HOSE WITH 1/4" GLOBE SHUT OFF VALVE AND 1/4" VENT VALVE WITH HEX NUT AND TAILPIECE (CGA-320)	
	1-026-0142	HOSE ASSEMBLY, CO ₂ CYLINDER FILLING 1/4" X 6' HOSE LESS VALVES WITH HEX NUT AND TAILPIECE (CGA-320)	

FIGURE & INDEX NO.	PART NO.	DESCRIPTION	UNITS PER ASSY.
3-2	<u>HAND WHEEL ASSEMBLIES</u> 1-907-0648	HAND WHEEL ASSEMBLY, 6" DIA EXTENDED NUT FOR CYLINDERS WITH SHROUD PROTECTED VALVES.	
	7-007-0001	HAND WHEEL ASSEMBLY, 2 1/2" DIA FOR STANDARD CYLINDERS.	
3-1	<u>VALVES, FITTINGS & HOSES</u> 1-061-0648	VALVE, FLIP TYPE BRASS 1/4" CAN REPLACE STANDARD GLOBE VALVES	
	1-026-0619	HOSE, 1/4 X 6' HIGH PRESSURE CO ₂ TRANSFER	
	5-039-0441	NUT, HEX, CO ₂ CYLINDER CGA 320	
	7-926-0221	TAILPIECE, CO ₂ CYLINDER CGA 320 W/O-RING	
	<u>SCALE</u> NS	PLATFORM SCALE BEAM TYPE OR ELECTRONIC 300 POUND CAPACITY X 1/4 POUND MINIMUM INCREMENTS.	

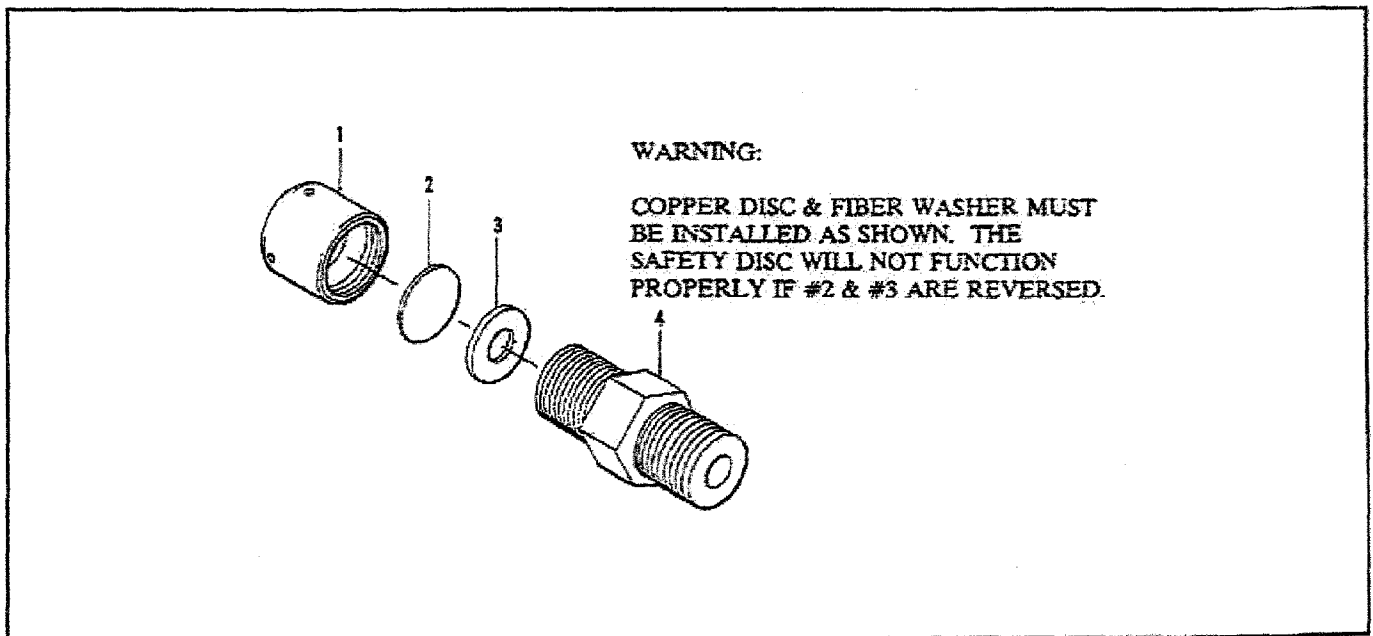

Fig. 4-1 Safety Disc Assembly

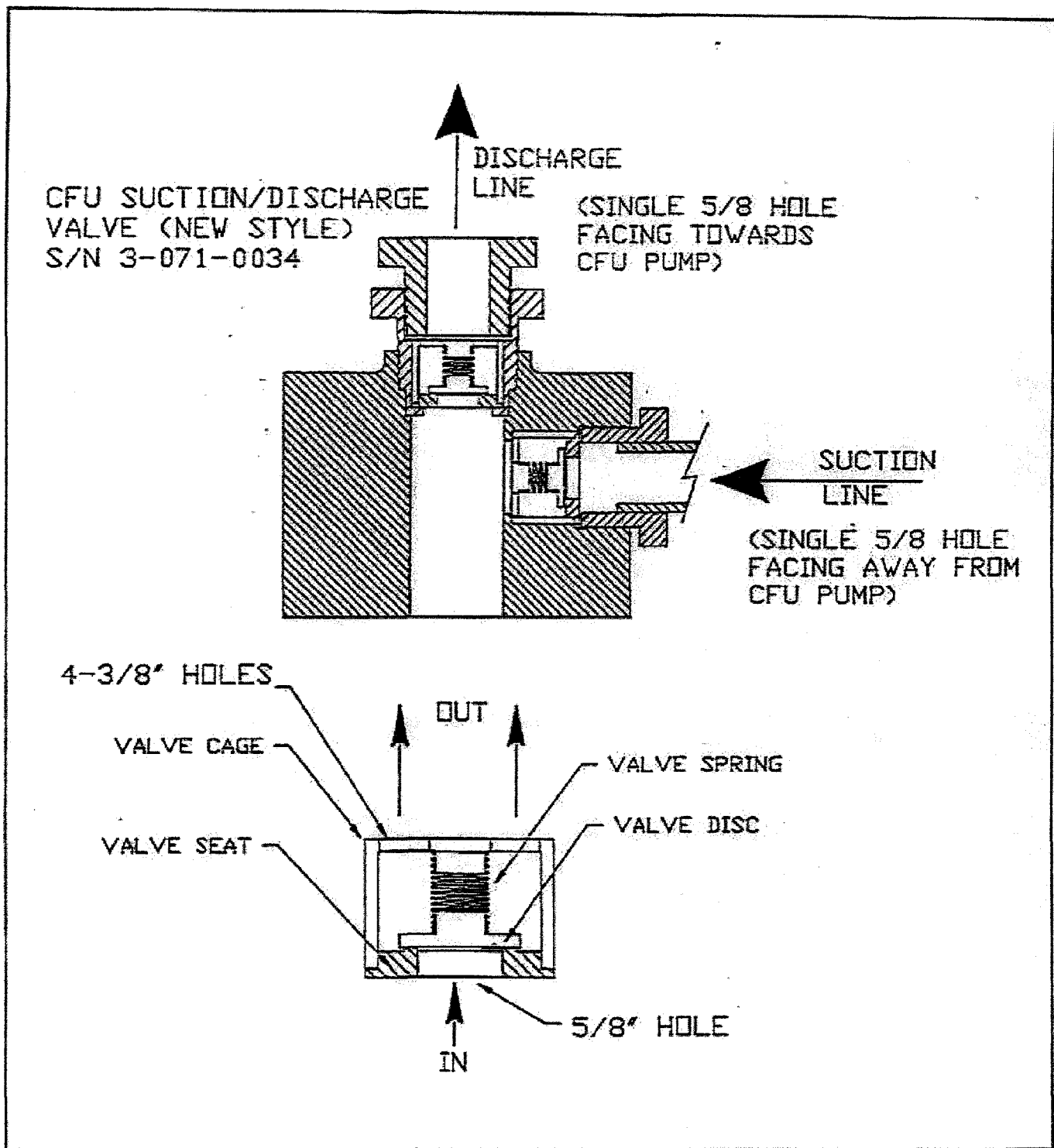

Fig. 5-1 Installation of Suction & Discharge Valves

SECTION V

PROPERTIES OF CARBON DIOXIDE

Carbon dioxide is nonflammable, colorless, odorless and non-corrosive. Carbon dioxide gas is approximately one and one-half times heavier than air and does not diffuse readily; therefore, ventilation is very important where carbon dioxide is being used to avoid danger to personnel. Liquid carbon dioxide exists only under pressure and boils, when released to the atmosphere to become a mixture of solid carbon dioxide (dry ice) and vapor at -109.3°F . At the instant of release, the discharge appears as a dense white fog of dry ice and condensed water vapor that disappears as the mixture warms.

Carbon dioxide may exist simultaneously as a solid, liquid and gas at its triple point which is at a pressure of 60.4 psig and a temperature of -69.9°F (-56.6°C). At atmospheric pressure solid dry ice transforms directly to a gas (sublimes without passing through the liquid phase).

At temperatures and pressures below the triple point, carbon dioxide may be either a solid ("dry ice") or a gas, depending upon temperature conditions. Solid carbon dioxide at a temperature of -109°F (-78.5°C) and atmospheric pressure transforms directly to a gas (sublimes without passing through the liquid phase).

SOLID CARBON DIOXIDE

Solid carbon dioxide (dry ice) has a temperature of -109.3°F (-78.5°C) and must be protected during storage with thermal insulation in order to minimize loss through sublimation. Dry ice should be stored in well-insulated storage containers, preferably in a cool, non-confined, or ventilated area.

Do not handle dry ice with bare hands. Use heavy gloves or dry ice tongs.

A suggested wording for a caution label for dry ice is as follows:

SOLID CARBON DIOXIDE (DRY ICE)

WARNING – EXTREMELY COLD

(-109°F)

Avoid contact with skin and eyes; use gloves. Do not taste. Keep out of children's reach. Liberates gas which may cause suffocation. Do not put in stoppered or closed containers.

CARBON DIOXIDE GAS

Carbon dioxide gas is 1.5 times denser than air and will accumulate in low or confined areas under certain conditions of use or storage. Precautions with regard to ventilation are required.

Appropriate warning signs should be affixed outside of those areas where high concentrations of carbon dioxide gas may accumulate.

Suggested wording for such a sign is:

CAUTION

CARBON DIOXIDE GAS

Ventilate before entering.

A high CO_2 gas concentration may occur in this area and may cause suffocation.

When entering low or confined areas where a high concentration of carbon dioxide gas is present, do not use air-breathing or filter-type gas masks. Gas masks of the self-contained type, or the type which supply outside air to the breathing mask, are required.

LIQUID CARBON DIOXIDE IN BULK CONTAINERS

Bulk containers for storing liquid carbon dioxide are well insulated mechanically refrigerated pressure vessels. Storage temperatures are maintained well below ambient temperatures, usually in the range of -20°F to +10°F (-28.9°C to -23.3°C) with corresponding carbon dioxide pressure of 200 to 345 psig (1379 to 2379 kph).

PHYSIOLOGICAL

Carbon Dioxide is normally present in the atmosphere to about 0.035 percent by volume (350 ppm). The exhaled breath contains up to 5.6 percent carbon dioxide. The greatest physiological effect of carbon dioxide is to stimulate the bodies respiratory system, thereby controlling the volume and rate of respiration. The OSHA approved CO₂ exposure level is 0.5% (5,000 ppm) for an 8 hour exposure.

EFFECTS OF OVEREXPOSURE

Gaseous carbon dioxide is an asphyxiant. Concentrations of 10 percent or more can produce unconsciousness or death. Lower concentrations may cause headache, sweating, rapid breathing, increased heart beat, shortness of breath, dizziness, mental depression, visual disturbances and shaking. The seriousness of these manifestations are dependent upon the concentration of carbon dioxide and the length of time the individual is exposed.

FIRST AID

If a person has inhaled large amounts of carbon dioxide and is exhibiting adverse effects, move the exposed individual to fresh air at once. If breathing has stopped, perform artificial respiration. Keep the person warm and at rest. Get medical attention at once. Fresh air and assisted breathing are appropriate for all cases of overexposure to gaseous carbon dioxide. Recovery is usually complete and uneventful.

If solid carbon dioxide (dry ice) or compressed CO₂ gas comes in contact with the body, stop the exposure at once. If frost bite has occurred, obtain medical attention. Immerse in warm (about 107°F) water. Do not rub.

If the eyes are involved, obtain prompt medical attention. The only appropriate first aid measure is a soft pad held in place over the affected eye.